

PRO 1000

The Production Depositor Rev 007

Designed to work over production lines and conveyors, the *PRO-1000* cake production depositor features an adjustable height mobile frame and diving nozzle with built-in suck back (prevents product from dripping) to accommodate full cover heads.

System Includes

- UNI-1000 Base fitted with a 3" (76mm) product cylinder and piston
- Large 14-gallon (52 liter) conical hopper
- 1.5 inch (38mm) diving cake nozzle with suck back, threaded to accept any Unifiller cream cover head
- Heavy duty all stainless steel construction mobile stand with built-in height adjustment
- Foot operated starter switch
- Removable Stainless Steel Tool Tray (as shown in picture on the stand).



Optional cream cover head shown in photo not included.



Product Cylinder Size Chart

CYLINDER SIZE	DEPOSIT VOLUME (fl oz)			
	Min		Max	
3"	3.6 oz	106 ml	36 oz	1064 ml
2.5"	2.5 oz	73 ml	24.5oz	726 ml
1.5"	0.8 oz	24 ml	8.2 oz	243 ml
1"	0.3 oz	10 ml	3.3 oz	99 ml

Shipping Information

Dimensions: 40"x 28" x 48" (101cm x 71cm x 122cm)
 Weight: 200 lbs. (91kg)

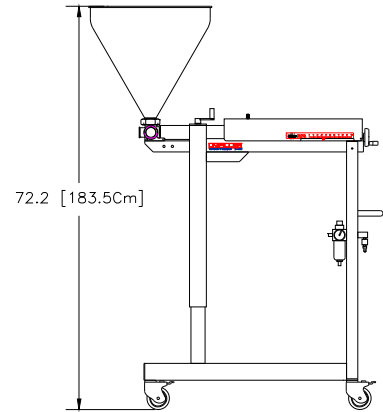
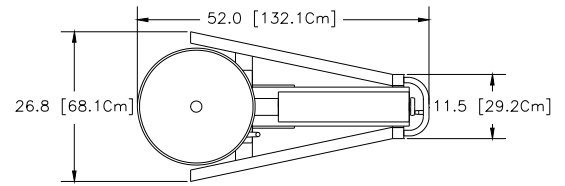

Performance Specifications



Speed
 Up to 140 Deposits/Min (8400 Deposits/hr)
 Based on product size.



Power
 Air only
 4 CFM @ 100 PSI
 113 litre/min @ 6.9 Bar



Volume
 0.3 – 36 oz.
 10 ml – 1064 ml



Particle Size
 Up to 3/4" cube
 Up to 19mm

Note: Equipment quoted is designed to run at the speeds given, but is dependent on operator efficiency and skill, as well as deposit size and product consistency.

Custom Cream Cover Heads

We custom manufacture a full line of cake heads for filling and decorating. Each head is built to your unique specifications. Ask your salesperson for a quotation on your specific requirements.



Options and Attachments (sold separately)

Locating Brackets



Spreader Nozzle



Optical Sensor



Work Table Attachment

