

# Apache 48x48 Pizza Press

## Specifications

* Length	15' 1" / 460cm
* Width	63" / 160cm
* Height	94" / 239cm
* Production Rate (depending on size)	Up to 10,800 crusts per hour
* Press Force	Fully adjustable
* Press Time	Fully adjustable
* Temperature Range	0° - 500° F
* Press Belt Speed	Fully adjustable
* Discharge Conveyor Speed	Fully adjustable

## Features

- \* Hinged guarding is fully interlocked for optimum operator and maintenance personnel safety.
- \* Allen Bradley Panel View touch control screen provides multi screen control at the touch of a button.
- \* Multiple Allen Bradley PLC controlled temperature zones for even heat distribution
- \* On board hydraulics are standard, optional centralized hydraulic systems available.
- \* Sanitary wash down frame design insures no standing water inside frame.
- \* Press Belt indexing is servo driven to accurately place product.
- \* Tens of Thousands of dollars less than comparable presses!
- \* Adjustable guide system eliminates lateral platen movement
- \* Replacement parts are standard items easily available.
- \* Open frame design allows easy access for cleaning and maintenance.
- \* Industrial, heavy gauge stainless steel tubular frame construction.
- \* Quick release belt tensioners for fast access to belt.
- \* Automatic belt tracking.
- \* Easy platen leveling to within thousandths of an inch.
- \* Platen travel is fully adjustable from 0" to 4".
- \* Temperature range up to 500\* F (260\* C).
- \* Full one year warranty.
- \* Integration of existing production equipment.
- \* CE Markings available.

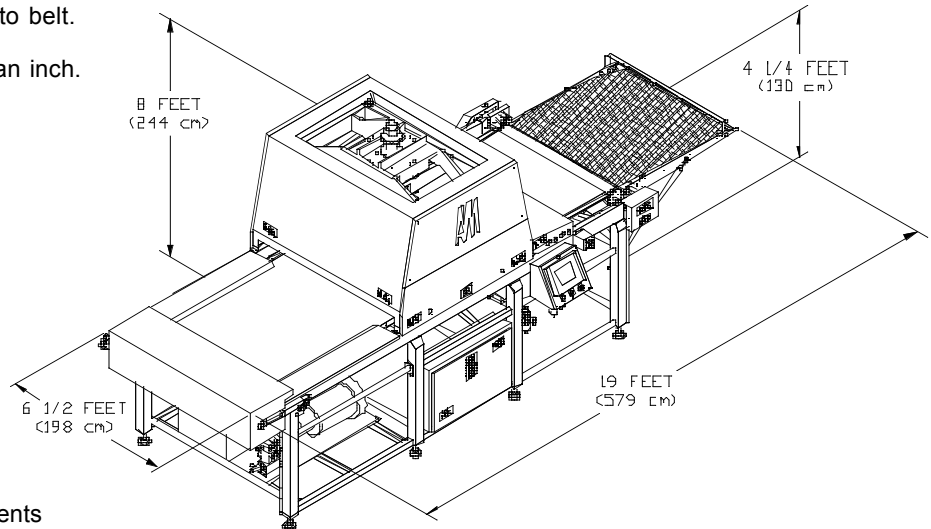

## Electrical Requirements

Please Call an AM Representative for Requirements



14151 Irving Avenue Dolton, IL. 60419  
 Phone: (708) 841-0959 or (800) 342-6744 Fax: (708) 841-0975

www.ammfg.com