

The Unifiller **Mini Depositor** is the modern solution for your dough depositing and extruding needs. It is built to do a wide range of products such as cookies, bars, stiff batters and pie dough. The feed auger is specially designed to be gentle on your product.

Benefits:

- **Easy to Clean** (only 4 parts)
- Portion control
- Cuts through inclusions – **BIG CHUNKS!**
- Produce up to 5400 deposits per hour
- Versatile - handles stiff batters that contain particulates (nuts, chocolate chunks, raisins or flavored chips)
- No heat transfer – no smearing and gentle on dough due to our single pitch auger drive
- Capable of sheeting up to 8" wide and 1" thick

Features:

- User friendly and easy to use control panel – pre program up to 20 recipes
- Rotary cutoff valve with various sizes of dies insets available
- Hopper capacity – 35 lbs / 15.5 kg
- Variable speed conveyor
- Stainless steel mobile "C" frame
- Photo sensor and foot pedal deposit switch
- Optional sheeting nozzle available
- Tool Free

Suggested Products:

- Gourmet Cookies
- Pie Dough
- Tart Dough
- Short Crust Pastry sheeting
- Scones (round)
- Biscuit (round)
- Marzipan
- Biscotti
- Fudge Brownie Batter
- Gluten Free Dough

PLC Mini Depositor

Mobile and Versatile Dough Depositor



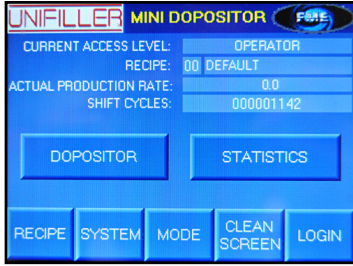

Easy to use control panel with recipe storage

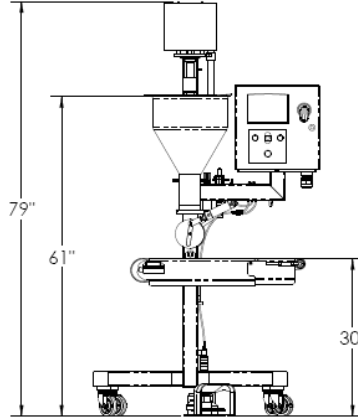

Various Die sizes

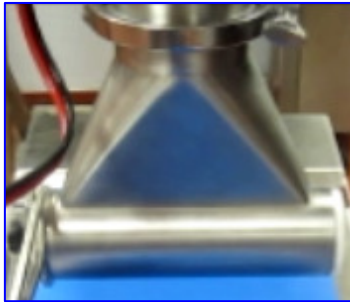

8" sheeting valve

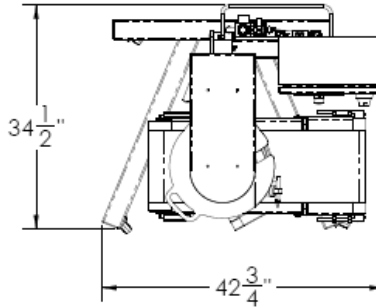

Rotary Valve

Performance Specifications:



Deposit Speed

Up to 90 cuts per minute, 5400 pieces per hour.



Power Requirement

Electric: 240 volt, 15 amp single phase
Pneumatic: 4 cfm @ 80psi (5.5 bar)



Deposit Width

Round : from 1/2 " to 3"
Sheet: from 1/8" to 1" thick and up to 8" Wide

Equipment Dimensions		
Height:	79"	200cm
Width:	42.75"	108cm
Length:	34.5"	87.5cm

Note: Equipment quoted is designed to run at the quoted speed and is dependent on operator efficiency, skill, and deposit size and product consistency.

Shipping Information:

Dimensions: 83" x 36" x 46" (211cm x 92cm x 152cm) Weight: 350 lbs (168kg)

Unifiller Systems North America and International

Head Office Canada
Phone: (604) 940-2233
Email: info@unifiller.com
Website: www.unifiller.com

Unifiller Systems UK Ltd.

United Kingdom
Phone: 01604 499846
Email: uk@unifiller.com
Website: www.unifiller.com

Unifiller Systems Europe GmbH

Germany
Phone: +49 7621 583 6310
Email: info@unifiller-europe.com
Website: www.unifiller-europe.com