

The **Hopper Topper Power Lift FS** transfer pump will help keep your production flowing smooth 24/7. With our gentle pumping technology, your product will be quickly transferred without sacrificing quality.

Benefits:

- Pump designed to simulate hand scooping (gentle on your product)
- Ergonomic power lift allows operator to change bowls with no lifting
- Optical product sensor allows you to maintain product level in hopper resulting in improved portion control and continuous production
- Versatility – fits most mixing bowls from 60-340 quarts
- Tool free disassembly for quick and easy clean-up

Features:

- 3" (76mm) diameter pump with 2" (50mm) outlet pipe work
- Start/stop air connection and fitting
- Mobile all stainless steel construction stand with adjustable height to suit customers mixing bowl
- Flow control to adjust pump speed for different products
- Ergonomic power lift technology

System Includes:

- Standard and extended depth versions available
- Start/stop air connection and fitting
- Automatic start/stop hopper level control sensor housed in a NEMA 4X control Box

HOPPER TOPPER POWER LIFT FS

How Do You Fill Your Hoppers?



Monitors product level in hopper

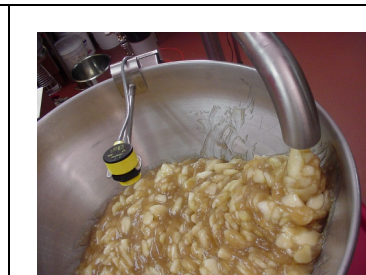

HOPPER TOPPER POWER LIFT FS

Specifications	Drawing	Power Lift Dimensions	Power Lift Extended Dimensions
Heights			
Power Lift Distance	A	28" (71 cm)	36" (91 cm)
Maximum (Ceiling) Height in Up position	B	114" (290 cm)	129" (328 cm)
Maximum bowl rim clearance in Up position	C	43" (109 cm)	45.3" (115 cm)
Maximum bowl bottom to floor clearance	D	15" (38 cm)	11" (28 cm)
Distance between Pump inlet and outlet (Maximum Bowl Depth)	E	24.5" (62 cm)	34.2" (87 cm)
Frame			
Inside Width	F	25" (63 cm)	32.4" (82 cm)
Bottom Frame Height	G	6" (15 cm)	6.7" (17 cm)
Pipe work reach	H	76" (193 cm)	76" (193cm)

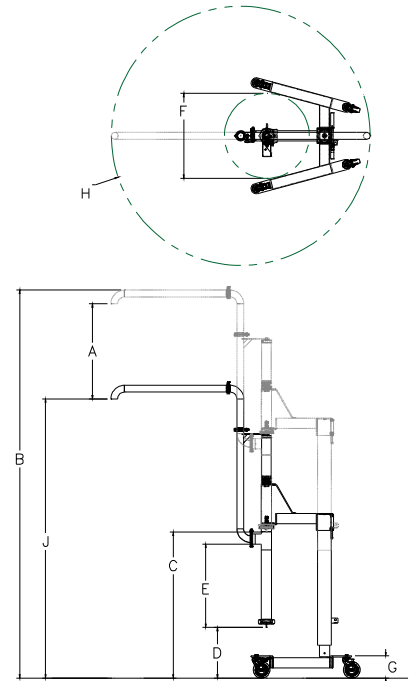

Shipping Information

Domestic

- Dimensions: L:42" x W:38" x H:75" (105 cm x 95 cm x 190 cm)
- Weight: 350 lbs (160 kg)

International

- Dimensions: L:52 x W:34" x H:20" (130 cm x 85 cm x 50 cm)
- Weight: 300 lbs (135 kg)

Performance Specifications

	<p>Speed Variable with Air Pressure Regulator</p>		<p>Power Air: 4 CFM @ 100psi (226.5 litres / min @ 6.9 Bar) Electric: 110 or 220 VAC, Single Phase, 1 A, 50-60 Hz</p>
	<p>Volume 3 to 13 US (11 to 49 liters) gallons / min.</p>		<p>Particle Size Up to 1" (25mm) cube soft fruit or similar</p>

Note: Equipment is designed to run at the speeds given, but is dependent on operator efficiency and skill, as well as deposit size and product consistency.