

# AO RB-RS

## SELF-TIPPING FORK MIXER

**MIXER**  
ART OF MIXING

PROFESSIONAL

### CAPACITY (kg)

- 230
- 330
- 440



### TECHNICAL DATA

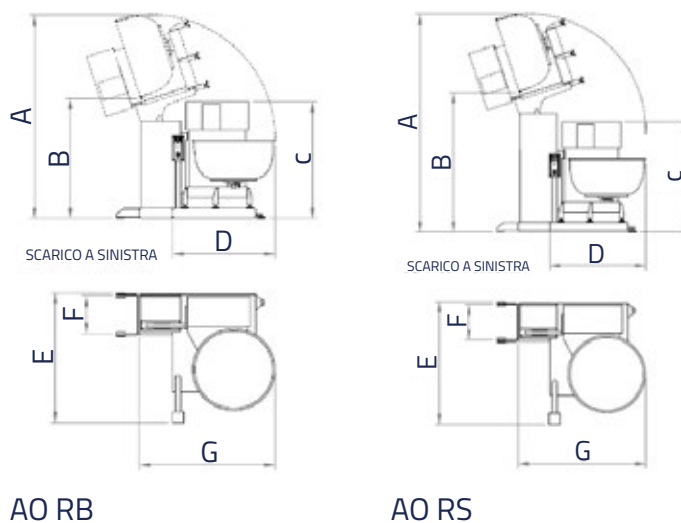

### DATI TECNICI

MODELLO		AO RB 230	AO RB 330	AO RB 440	AO RS 230	AO RS 330	AO RS 440
Dough capacity (min./max) *	kg	35/120	50/180	45/250	35/120	50/180	45/250
Flour capacity (min./max) *	kg	22/75	32/110	26/165	22/75	32/110	26/165
Water capacity (min./max) *	lt	13/45	18/70	18/85	13/45	18/70	18/85
Bowl volume	lt	230	330	440	230	330	440
% water/flour minimum	%	50	50	50	50	50	50
Spiral turns 1st / 2nd speed (50/60Hz)	rpm	47/70	47/70	47/70	47/70	47/70	47/70
Bowl turns 1st / 2nd speed (50/60Hz)	rpm	-/-	-/-	-/-	-/-	-/-	-/-
Motor power 1st / 2nd speed	kw	3.7/5.2	3.7/5.2	4.6/6.9	3.7/5.2	3.7/5.2	4.6/6.9
Current drawn V 230/400	A	19	19	26	19	19	26
Current drawn V 230/400	A	11	11	14.7	11	11	14.7
Total height (during discharging phase)	A mm	2330	2410	2500	2580	2660	2810
Height from bowl edge (during discharging phase)	B mm	1380	1360	1330	1636	1610	1650
Total height (machine to the ground)	C mm	1340	1340	1530	1340	1340	1530
Total width	D mm	1086	1175	1250	1086	1175	1250
Total depth	E mm	1480	1480	1650	1480	1480	1650
Depth from lateral support	F mm	420	460	460	420	460	460
Total width	G mm	1550	1633	1730	1550	1633	1730
Net weight	kg	850	890	1150	1050	1100	1320

\*: capacity based on the percentage of liquid/flour = 60%

All data are to be considered as nominal, MIXER srl reserves the right to make any changes to the product and/or technical specifications without notice.