

## VMRF EXTRUDER

Belshaw's Vacumatic (VMRF) yeast-raised donut extruder deposits ring donuts automatically onto Belshaw's Thermomatic Proofer. Dough is placed into the VMRF hoppers and is automatically deposited on the proofer trays - eliminating the need for a make-up line and the associated kneading, rolling and cutting.

With the VMRF extruder, fresh dough is added to the depositor continuously, eliminating the downtime associated with replenishing pressure cutters and improving efficiency up to 25%.

Belshaw's VMRF is designed to be durable even in tough high-volume production environments. This durable construction produces a round, uniform ring donut reliably - time after time.

### Features

- Fast, no-tools-required, clean-up.
- Automatic synchronization with donut proofer.
- Deposit weight is adjustable between 1.5oz to 3oz (35g to 70 g)
- Different size models available to extrude from one to 10 donuts simultaneously.
- Designed for fryers from 2 to 10 full-sized donuts across, up to 22,000 pieces per hour.
- Mountable on Mobile Lift Carrier with electric or manual height adjustment.



Top; Belshaw Vacumatic VMRF-4 with Century TM200 automatic proofer



Above; Belshaw Vacumatic VMRF-8 with Century TM800 automatic proofer



Above; Belshaw Vacumatic - deposits ring donuts directly to automatic proofer

Vacumatic Diagrams

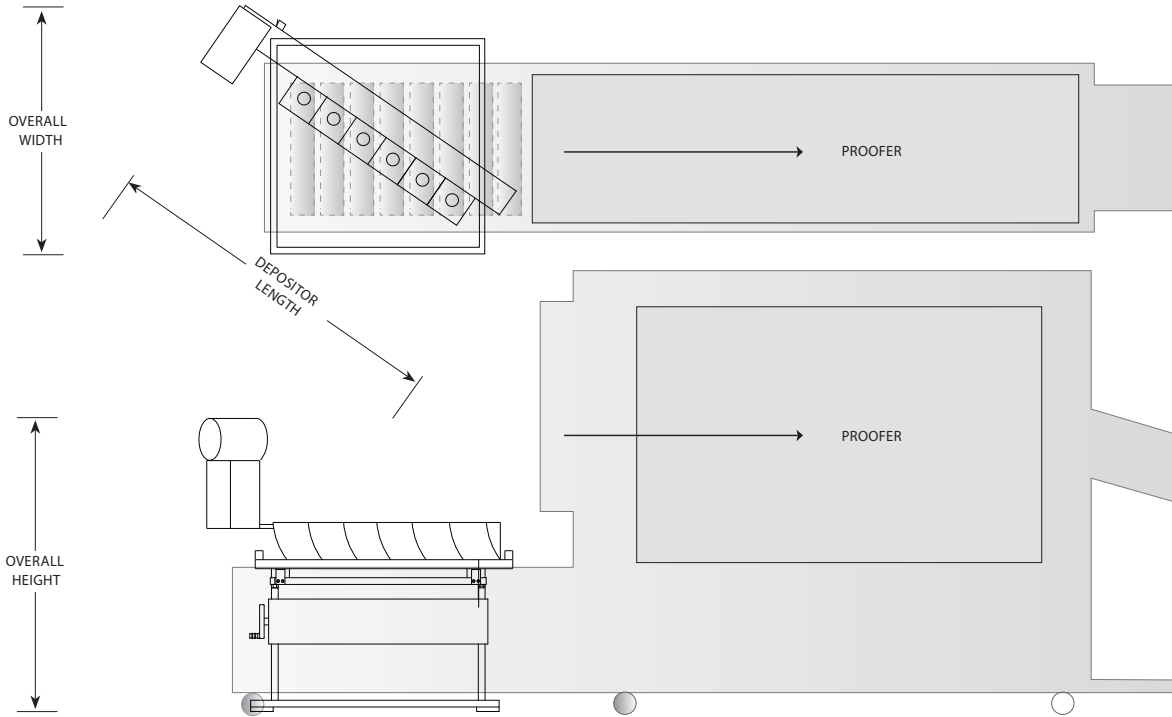

Dimensions And Power Requirements

MODEL	SYSTEM	NUMBER OF DONUTS PER CYCLE	DIMENSIONS (WITH MOBILE CARRIER)			HOPPER CAPACITY	APPROX SHIPPING WEIGHT <sup>1</sup>	ELECTRICAL
			DEPOSITOR LENGTH	CARRIER WIDTH	OVERALL HEIGHT			208/240V 50/60Hz 1ph
VMRF-1	Kettle fryer	1	25in (0.64m)	10in (0.25m)	36in (0.91m)	20lbs (9kg)	180lbs (82kg)	3.4 A
VMRF-4	C6-16/C10-16	4	74in (1.88m)	42in (1.07m)	76in (1.93m)	80lbs (36kg)	1650lbs (750kg)	6.6 A
VMRF-6	C6-24/C10-24/C14-24	6	88in (2.24m)	52in (1.32m)	77in (1.96m)	120lbs (55kg)	1950lbs (886kg)	7.4 A
VMRF-8	C10-36	8	96in (2.44m)	64in (1.63m)	79in (2.01m)	160lbs (73kg)	2350lbs (1068kg)	9 A

Notes

- 1 Shipping weight includes carrier (except for VMRF-1 which uses a stationary table)
- 2 All weights, dimensions and electrical data should be considered as estimates only. Discuss with your Belshaw Industrial Sales Manager.

VMRF PLUNGERS

The action of the Vacumatic plunger is designed to minimize stress on the actively rising dough. Plunger sets for Century Vacumatic (VMRF) models are precision-made from high quality stainless steel. For ring donuts in three sizes, using plunger diameters 1-1/8in (29mm), 1-1/4in (32mm) and 1-3/8in (35mm).



Right: Plungers for Vacumatic (VMRF)