

The Unifiller Syrup Sprayer automatically sprays portion controlled liquid syrup onto cake layers.

Syrup Spray Module

Moisture and flavor create the best cake layers

Benefits:

- Targeted, automatic syrup spray application
- Accurate portion control
- Even syrup distribution
- Less syrup usage
- Easy to clean — less equipment and facility sanitation required

Features:

- All stainless steel food grade construction
- 45" conveyor food grade conveyor belt with ability to carry products from small up to 12" cakes
- Adjustable side guide rails
- Integrated outfeed carry-over roll for transferring small products to next process
- Splash shields
- Stainless steel catch tray with support for overspray container
- Sanitary pumping system with 5 US gal (19 liter) quick change product tank
- Airless spray nozzle with two interchangeable nozzle tips
- NEMA 4X stainless steel enclosed control system
- Conveyor modes: Continuous and Stop-and-Go
- Optical top down photo sensor



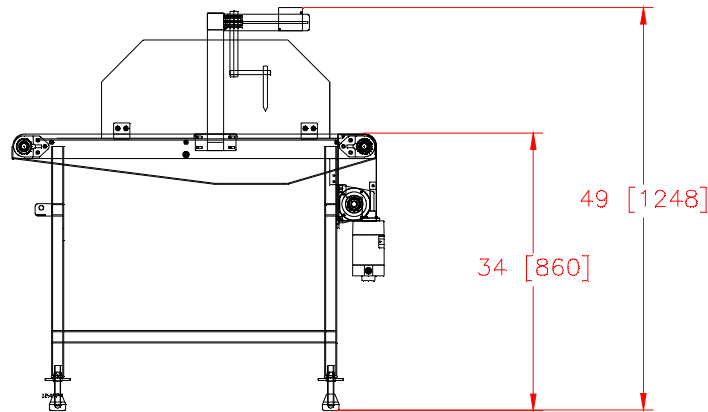
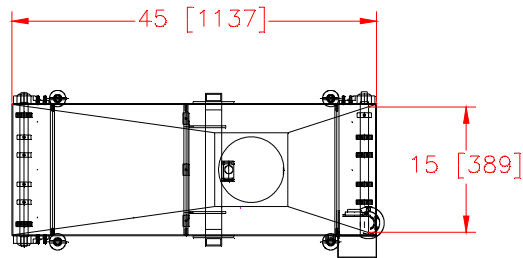

Performance Specifications:



Speed: Up to 700 cakes per hour single lane



Power:
Air: 1 CFM @ 80 P.S.I

Electrical: 110 VAC or 220 VAC, single Phase (non GFI)



Volume:
Up to 0.5 gallons (1.9 liters) per minute

Cake Sizes

Round Cakes: 3-12" (76mm-304mm)
Rectangular: up to 14" wide (35 cm)

Shipping Information

Dimensions:

48" x 32" x 54" (122 cm x 81 cm x 137 cm)

Weight:

320 lbs. (145 kg)

Note: Equipment quoted is designed to run at the quoted speed and is dependent on operator efficiency, skill, and deposit size and product consistency.