

Cake Finishing Center

All in One Cake Decorating Station



The Cake Finishing Center is a computerized icing and decorating system that applies icing to the top and sides of your round cakes, then finishes the cakes with shell borders or rosettes.

Benefits:

- Can finish a cake on one single station.
- The advanced icing control system automatically monitors and adjusts for changes in icing consistency from batch to batch.
- On-board computer using touch-screen controls can store recipes for various styles of finishing.

Features:

- Advanced icing control feedback system
- Allen-Bradley controller and panel view touch screen display, mounted in an all-stainless steel NEMA-4X control box (store up to 20 different recipes in memory)
- Cake Touch-Up Function Button
- Telescopic height adjustment mechanism for quick and easy fine-tuning of deposit height

System Includes:

- Choice of one small or large size adjustable turntable
- Choice of two product cylinders



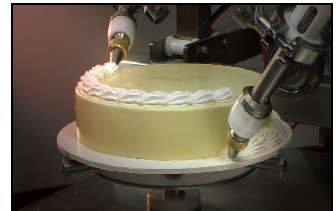
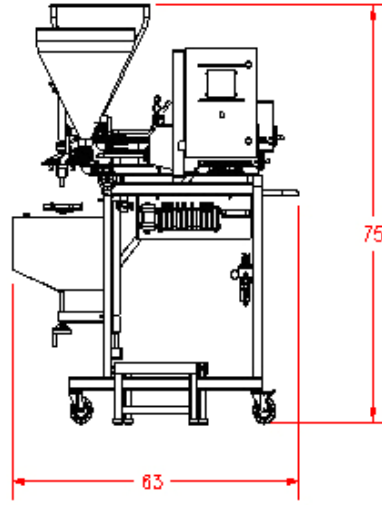
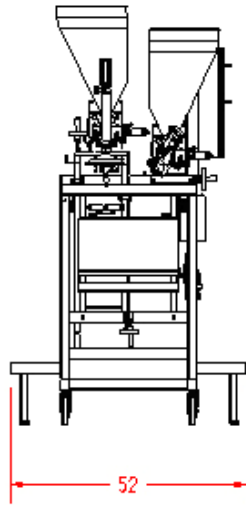





Optional Decorating Attachments:

- Top and Side Icing Nozzle
- Mid Fill Nozzle
- Top and Bottom Bordering Nozzles
- Cake Decorating Heads (requires Diving Nozzle)

Shipping Information

- Dimensions: 67" x 56" x 75"
(170cm x 142cm x 190cm)
- Weight: 375 lbs (170 kg)

Performance Specifications:

 <p>Speed Up to 7 cakes per minute</p>	 <p>Power Air: 6 CFM @ 100psi 170 liters / minute @ 6.9 Bar Electrical: 110V AC/ 15A</p>
 <p>Cake Sizes 5 – 12" round, up to 5.5" tall 12.7cm – 30cm round, up to 14cm tall</p>	 <p>Computer Allen Bradley Control panel with touch screen display</p>

Note: Equipment quoted is designed to run at the quoted speed and is dependent on operator efficiency, skill, and deposit size and product consistency.