



200
250
300
400
500

INDUSTRIAL SPIRAL MIXER WITH REMOVABLE BOWL

Reliable, minimal maintenance requirements

Efficient solutions and quality component parts

Produces high quality dough

High productivity performance

INNOVATIVE TRANSMISSION SYSTEM FOR THE BOWL MOTOR: NO REDUCTION GEARS

After analysing the important features of machines already on the market in this sector, we have developed a new, more flexible transmission system for the bowl. Rigid reduction gears have been replaced by more flexible parts, belts and wheels, to give a more reliable end product.

A series of solutions introduced to drastically reduce maintenance has made the machine an ideal option for artisan and continuous cycle industrial products.

AN EFFICIENT SOLUTION: SELF ADJUSTING TRANSMISSION WHEELS FOR THE BOWL

A characteristic feature of the Mixer range which allows the wheels maximum adherence to the bowl quite independently of any eventual wear and tear.

DOUGH QUALITY: DELICATE, EXACT, HOMOGENEOUS

Almost thirty years of Mixer experience lies behind the machines proven ability to mix and produce optimum mixing for bread, pizzas, croissants, and panettones to name but a few of the products tried and tested to date.

Machines can be adjusted to client's requirements on request.

COOLER TEMPERATURES FOR DOUGH

The Mixer spiral demonstrates its maximum efficiency in the high number of efficient beats executed, which gives cooler temperatures and refined doughs.



PRO.E BAGEL REMOVABLE BOWL SPIRAL MIXER TECHNICAL FEATURES

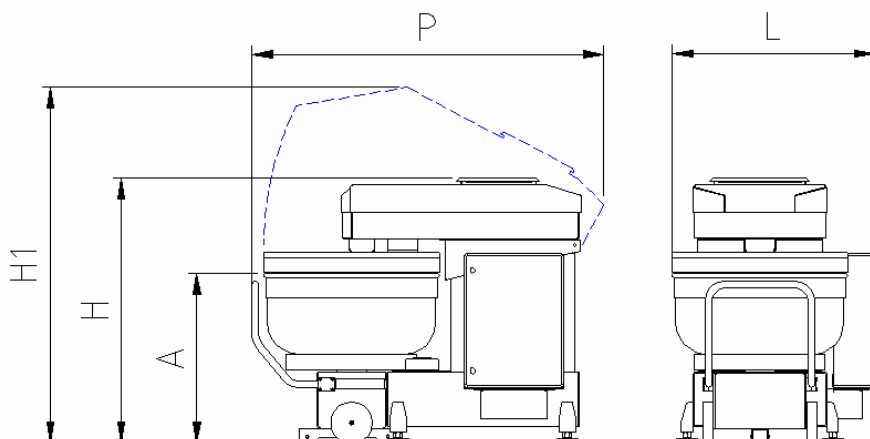

Model		PRO.E 200 BAGEL	PRO.E 250 BAGEL	PRO.E 300 BAGEL	PRO.E 400 BAGEL	PRO.E 500 BAGEL
Dough capacity (min./max) *	Kg	15/200	15/250	20/300	30/400	40/500
Flour capacity (min./max) *	Kg	9/125	9/150	12/185	18/250	24/300
Water capacity (min./max) *	Lt	6/75	6/100	8/115	12/150	16/200
Bowl volume	Lt	320	380	470	600	700
% Water/flour minimum	%	45	45	45	45	45
Spiral turns 1st speed (50/60hz)	rpm	90	90	90	92	92
Spiral turns 2nd speed (50/60hz)	rpm	182	182	182	184	184
Bowl turns 1st speed (50/60hz)	rpm	8	8	8	8	8
Bowl turns 2nd speed (50/60hz)	rpm	16	16	17	16	16
Motor power 1st speed	kw	11.1	11.1	12.6	15.8	17.3
Motor power 2nd speed	kw	16.6	16.6	17.1	23.6	25.1
Input current V. 230	A	56	56	58	80	84
Input current V. 400	A	33	33	34	47	49
Spiral bar diameter	mm	60	60	60	60	60
Height from bowl lip	A mm	960	1020	1036	1090	1090
Total length	P mm	2110	2110	2210	2330	2430
Total width	L mm	1220	1220	1270	1320	1400
Total height	H mm	1585	1585	1585	1640	1640
Total height with machine open	H1 mm	2150	2150	2150	2350	2350
Net weight	kg	1610	1640	1730	2000	2110

*: capacity determined in view of % liquid/flour equal to 60

SUPPLIED STANDARD EQUIPMENT

Bowl, contrast column, safety guard and flour screen made of AISI 304 stainless steel	Two timers setting the working time with automatic shift from 1st to 2nd speed
Spiral made of AISI 431 stainless steel	Selector for reverse bowl rotation device at 1st speed
Movement transmission to the spiral through pulleys and V belts, to the bowl through two friction wheels	Selector for plugging in of 2nd bowl speed
Head lifting/descent and release/connection of the trolley through oil-pressure cylinders	Push button for machine head lifting/release of the trolley with the presence of the operator
Structure made of ral 9007 grey coated steel	Push button for machine head descent/connection of the trolley with the presence of the operator
Bowl thrust rollers	Tension 400 V - frequency 50 Hz - 3 phases
Spiral shaft bearings cover	Four meters of cable with CEE plug
Trolley with bowl on wheels	Operating/Maintenance instructions and CE statement of Compliance
Overvoltage and overload motor protection	Pallet packaging with nylon
Closed dust guard	

OPTIONAL EXTRA EQUIPMENT

Stainless steel structure	Bowl scraping device
Extra-bowl carrying trolley	Micro-ingredients automatic introduction tanks controlled by computer
Programmable computer for setting of recipes phases	Bowl oiling system controlled by computer
Contact probe for sensing the kneading temperature	Controls on left side
Power meter	Small opening for water loading
Dry ice blowing in: dough cooling system with CO2 injection	Small opening for flour loading
Automatic opening at the end of cycle	Special voltage/Frequency: 230/50/3 220/60/3 380/60/3
	Wooden crate



45 Garema Circuit, Kingsgrove NSW 2208 Australia
t. +61 2 9740 5122 f. +61 2 9740 5237
e. info@rvo.com.au