

NORMAL

MULTIDROP®

**MODEL
"Classic"**



Multidrop® is a depositor, a dosing machine and a wire cut machine.

Thanks to the 100 programs computer with LCD you can make a wide range of biscuits and confectionery products. - Brasilians - Champagne biscuits - Shortbread Dough - Shortcakes - Ciambelline - Danish cookies - Sables - Amaretti - Soft amaretti - Macarons - Petit fours - Baci di dama - Brutti e buoni - Coconut biscuits - Canestrelli - Occhi di bue - Chocolate chip cookies - Krumiri - Gingerbread - Offelle - Cantucci - Ricciarelli - Kipfels - Novellini - Palets.*

* this list only includes the most popular products

ALL THE MULTIDROP® CLASSIC NORMAL ARE EQUIPPED WITH:

- STAINLESS STEEL STRUCTURE AND ROTATING WHEELS WITH BRAKE
- EASILY DETACHABLE TABLE.
- HEAD EASY TO DISASSEMBLE AND WASH.
- HEAD WITH STAINLESS STEEL ROLLERS, WITH ADAPTORS FOR HARD AND SOFT DOUGHS.
- WIDTH OF THE HEAD SUITABLE FOR WORKING WITH TRAYS WITH WIDTHS OF 400 TO 460 AND FROM 600 TO 660 MM.
- POSSIBILITY OF FITTING DIFFERENT HEADS BASED ON THE PRODUCTS.
- COMPUTER WITH 100 PROGRAMS WITH LCD AND LIGHT ADJUSTMENT
- MOTOR WITH INVERTER FOR ROLLER ROTATION
- MOTOR FOR NOZZLE ROTATION (NR-NL ONLY).
- MOTOR FOR TABLE LIFTING WITH SERVOASSISTED POSITIONING.
- MOTOR WITH INVERTER FOR AUTOMATIC TRAY ADVANCING.
- MOTOR FOR ACTIVATION OF WIRE CUTTING (NL ONLY).
- "CE" COMPLIANCE CERTIFICATE.

Reseller stamp:



POLIN



Ing. Polin & C. S.p.A.
V.le Dell'Industria, 9 - 37135 Verona ITALY
Tel. +39 045 8289111 - Fax +39 045 8289122
www.polin.it polin@polin.it

DIMENSION (mm):

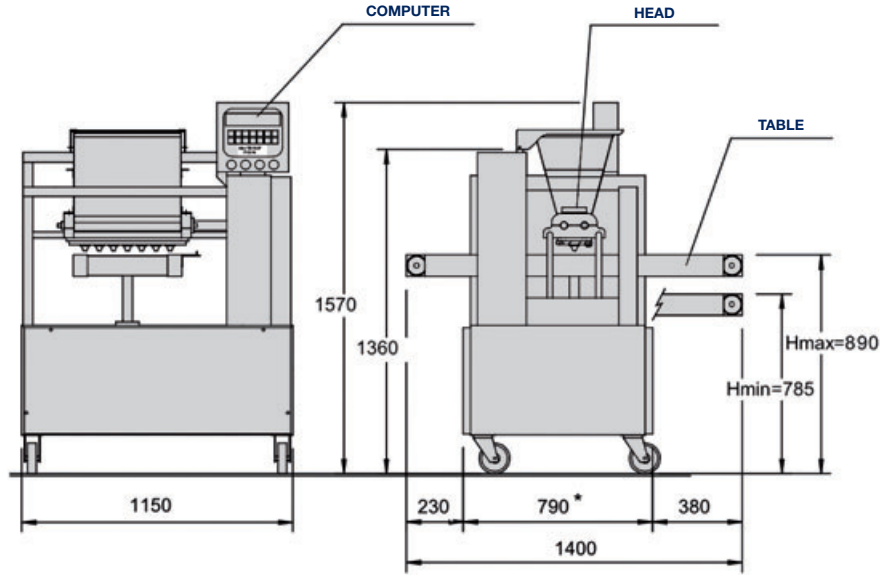
Multidrop® Classic Normal NE - NR - NL



*MINIMUM DIMENSION WITH TABLE REMOVED FOR DOOR PASSAGE

TRAY DIMENSIONS, TECHNICAL DATA, PERFORMANCE AND PACKAGING PER MODEL:

Multidrop® Classic Normal NE - NR - NL							
Models:	NE		NET		NR		
TRAY DIMENSIONS							
Width (mm)	400 - 460	600 - 660	400 - 460	600 - 660	400 - 460	600 - 660	
Length (mm)	400 - 800						
TECHNICAL DATA							
Standard voltage (Volt)	400/3N~/50						
Optional voltage (Volt)	230/3~/50 - 220/3~/60						
Power (kW)	1,37	1,37	1,62	1,62	1,71	1,71	
Weight (Kg) net	300	305	310	315	320	325	
Hopper capacity (Litres)	35	50	35	50	35	50	
Noise level (dB)	<80						
PERFORMANCE							
RPM (max cycles/1')*	20		20		20		
Wire cut (max cycles/1')*					30		
DIMENSIONS AND WEIGHTS							
Packaging (mm)		1550x1300xh=1750					
Packaging (Kg)	gross	480	485	490	495	500	505
Packaging (mm)		1600x1350xh=1800					
Packaging (Kg)	gross	550	555	560	565	570	575
Packaging (mm)		1500x1250xh=1450					
Packaging (Kg)	gross	460	465	470	475	480	485

*Related to an average rollers rotation time of approx. 1 second.

EQUIPMENT: HEADS



Roller head for hard dough



Roller head for “American” type hard dough



Pump head for soft dough



Pump head for soft dough, with alternating teeth gears

EQUIPMENT: ACCESSORIES



Dies and nozzles



Paper holding device



Squashing tips device



Memory card and Cd Proges Software