

180

UNTIL BOWLS
WITH
CAPACITY
300 kg - 280 l



LIFTER FOR BOWL
TROLLEYS
DUMPER ON
DOUBLE
DISCHARGE SIDE

Versatile

Double offloading
side

Reliable and safe

MIXER has introduced a new addition to its line of mixers with removable bowl trolleys – a complete new line, the BLT lifter-dumper, a reliable piece of equipment with hydraulic function.

BLT lifter-dumpers are robust and versatile, designed to cater for the different requirements of artisan bakers and confectioners, and can be used both with MIXER removable bowl models as well as with models made by other manufacturers.

The BLT DS lifts bowl trolleys and can empty bowl contents either left or right according to the loading direction of the trolley. This allows for use with two production lines contemporaneously.

Special requirements or features of production lines are not a problem: MIXER technical personnel and designers can use their experience to provide clients with tailored solutions to suit their requirements.

OPTIONALS

The BLT DS lifter can be fitted with special connections for non-MIXER trolleys and with semi-automatic controls. In this case the cycle requires human presence for the last section of the descent, which is activated by pressing a button. Structure can be manufactured partially in stainless steel.



BLT DS

BOWLS LIFTER-DUMPER WITH DISCHARGE ON BOTH SIDES

TECHNICAL FEATURES

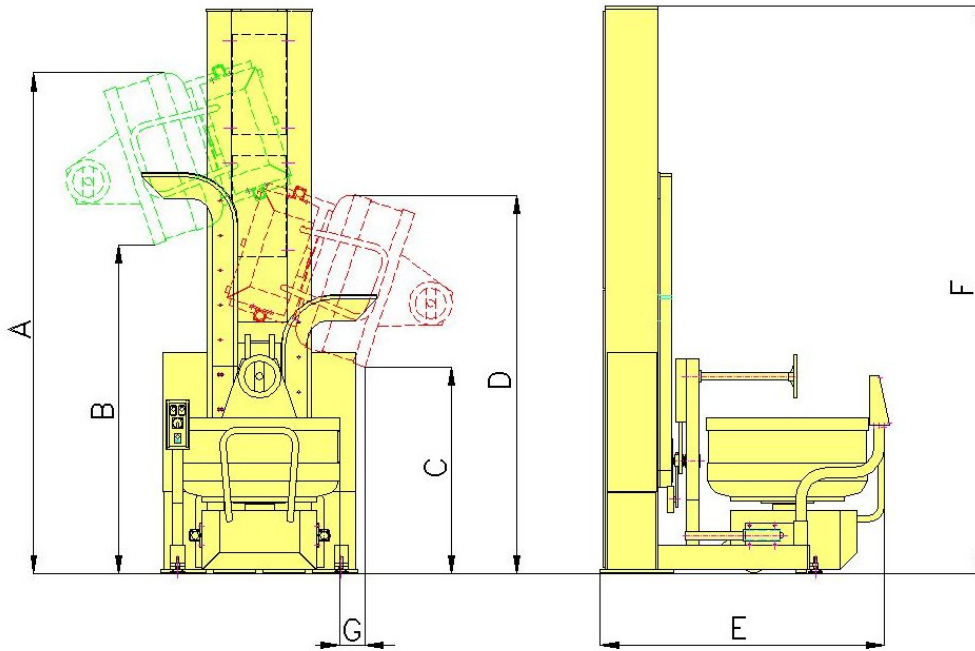

TECHNICAL DATA

COUPLED EXTRA-BOWL CARRYING TROLLEY		C/130	C/160 – 200	C/250	C/300
Maximum height with trolley during overturning phase	A mm	2940	2980	3040	3090
Maximum height from bowl lip with trolley during overturning phase	B mm	2050	1980	1890	1830
Minimum height from bowl lip with trolley during overturning phase	C mm	1250	1190	1250	1230
Minimum height with trolley during overturning phase	D mm	2140	2290	2350	2440
Total length	E mm	1500	1600	1700	1800
Total height	F mm	3230	3230	3230	3230
Bowl exit	G mm	130	130	220	220
Input current V. 230	A	4.6			
Input current V. 400	A	2.5			
Motor power	Kw	1.0			
Net weight	kg	780	780	830	830

SUPPLIED STANDARD EQUIPMENT

Structure made of grey steel ral 9007 coated for combinations mod. C/FOR.E, C/PRO.E, C/AF or structure made of white steel ral 9002 coated for remaining models included couplings of trolleys not produced by us	Lifting system by oil-pressure cylinder
Height adjustable dumpingways	Tension 400 V. – frequency 50 Hz – 3 phases
Manual handwheel for selection of discharge side	Four meters of cable with CEE plug
Controls push button panel on movable support	Operating/Maintenance instructions and CE statement of Compliance
Overvoltage and overload motor protection	Pallet packaging with nylon

OPTIONAL EXTRA EQUIPMENT

Partial stainless steel structure (base plate, legs and electric board), the remaining parts steel grey ral 9007 coated	Special connections for trolleys which are not produced by our company
Semiautomatic controls (automatic rise partial automatic descent)	Machine white steel ral 9002 coated for couplings mod. C/FOR.E, C/PRO.E, C/AF or machine grey steel ral 9007 coated for remaining models
Couple of connections for lifter with side discharge (1 for each trolley)	Wooden crate

TROLLEYS TO BE COUPLED

C/ASE 130-160-200-250-300	C/AOE 230-330
C/PRO.E 200-250-300	C/AOTE 230-330
C/AF 240-300	C/IBT.E 130-160-200-300
C/FOR.E 160-240-320	